



www.casambi.com



Casambi Knowledge Base



Download FREE Casambi
iOS/Android App



Specification Library

Project: _____

Reference Type: _____

Item Code: _____

Date: _____

Notes: _____

PIR Fixture Mount Sensor 120/277VAC

Overview

- PIR Hi/Low Bay Sensor
- 100-277VAC Input Voltage
- Casambi Wireless Mesh
- 0-10V Output to LED Driver
- High-End Trim, Zoning, Continuous Dimming
- Relay with Zero Crossing
- LED Motion indicator
- Mounting height up to 40ft (12.2m)
- 360° coverage pattern
- ioXt Alliance cybersecurity certification



Shown with optional mounting arm
Suitable for Indoor Use Only



Applications

The PSC-BL-I-FM-100-BLE-CB can accept universal input (120-277 VAC) to use the PIR Motion Detector Architecture and passive infrared (PIR) technology for improved detection coverage for high bay, and low bay applications.

The PSC-BL-I-FM-100-BLE-CB is a Class 2 Device designed to satisfy CA Title 24 requirements for dimming of lighting fixtures. The occupancy sensor will shut the light off with the built in relay.

The sensor is suitable for a variety of indoor applications including parking garages, warehouse aisles, and library stacks. It supports fixture and ceiling mounts up to 40 ft (12.2 m) high. The sensor is rated for use in temperatures ranging from 30° to 60°C and relative humidity from 90 to 95% at 30°C.

The optional sensor arm is ideal for end of warehouse aisles and library stacks to conform with CA Title 24 cutoff requirements.

Sensor Operation

Casambi Wireless Mesh Controls: The sensor connects to a wireless mesh network via a mobile app, available as iOS or Android, to allow initial setup and subsequent parameters adjustments.

User Interface: Using the mobile app, features include: setup, control real time feedback, and scheduling without a gateway or internet access.

Dimming: 0-10V dimmer connects to 0-10V control on the LED driver.

Relay: Zero Cross Switching Relay built in for load control.

See the mwConnect Casambi User Manual for more info.

Summary

Sensor Type:
PIR occupancy/vacancy sensor

Input Voltage:
100-277VAC, 2W (no-load)

Max Load:
240 VA @ 120VAC, 2A E-Ballast
554 VA @ 277VAC, 2A E-Ballast

0-10V Output: 60 mA

Mounting Height:
Fixture mount up to 40ft (12.2m)

Max Sensor Range:
40ft (12.2m) radius

Max Wireless Range¹:
100ft (30.4m)

Operating Temperature:
-20° C to 60°C

Storage Temperature:
-40° C to 80°C

Relative Humidity:
90-95% non-condensing at 30°C

Color: White

Warranty: 5 years

Note:

1. Wireless Range is highly dependent on the integration of fixtures, surrounding environment and conditions. It is recommended to conduct testing for range accuracy.



www.casambi.com



Casambi Knowledge Base



Download FREE Casambi
iOS/Android App



Specification Library

Project: _____

Reference Type: _____

Item Code: _____

Date: _____

Notes: _____

Physical Dimensions

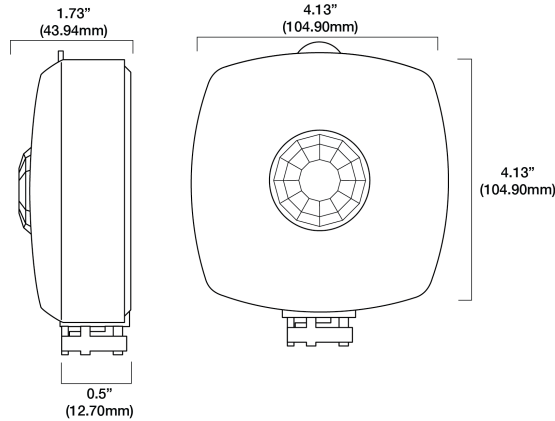

Drawings are Not to Scale

Assembly

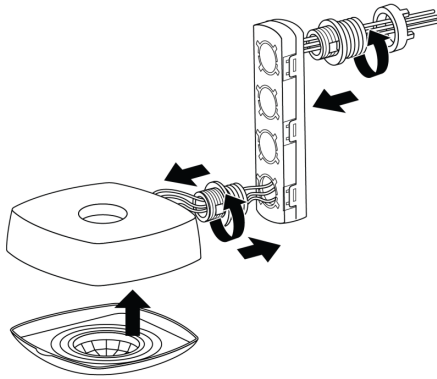

Shown with Mounting Arm (optional)

Mounting Arm (optional)

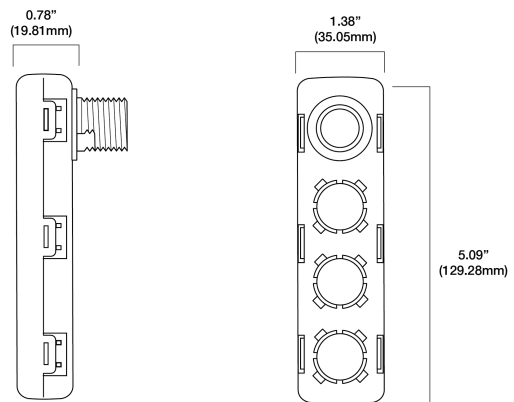

Wiring Diagram

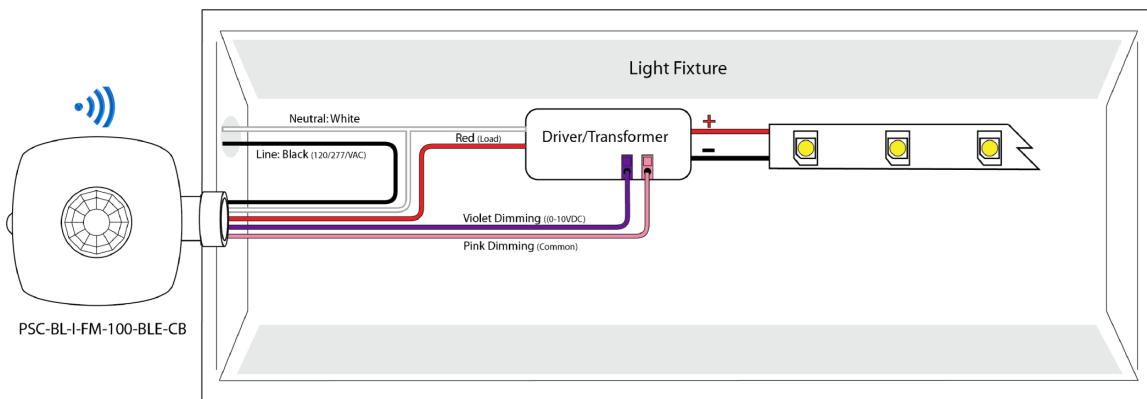

* Effective 2021 per NEC change, 0-10v signal wires will be purple/pink. Devices manufactured prior to 2021 may be purple/grey and still used in field.

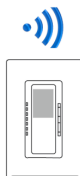

PSC-BL-I-FM-100-BLE-CB
Line Voltage Power Pack/PIR Sensor,
0-10V Dim to Off Driver, and Wireless Switch



www.casambi.com



Casambi Knowledge Base



Download FREE Casambi
iOS/Android App



Specification Library

Project: _____

Reference Type: _____

Item Code: _____

Date: _____

Notes: _____

Detection Area

HBL: HighBay Lens - Top View at 8 ft (2.4m)

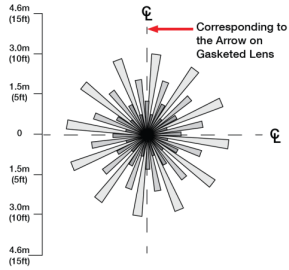

HBL: Side View

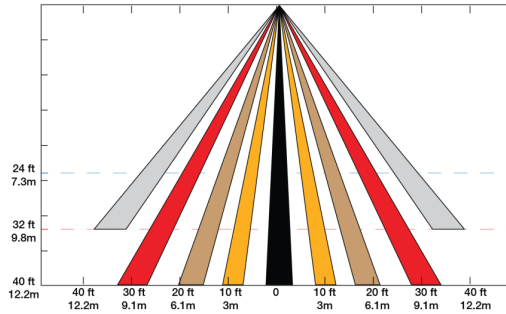

LBL: Low Bay Lens - Top View at 8 ft (2.4m)

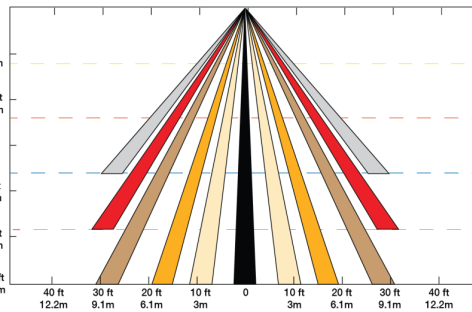
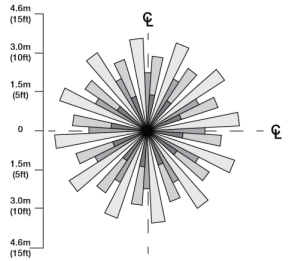

LBL: Side View

Masking

AL1: Center aisle lens cover

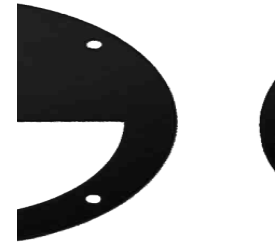

AL2: End of aisle lens cover

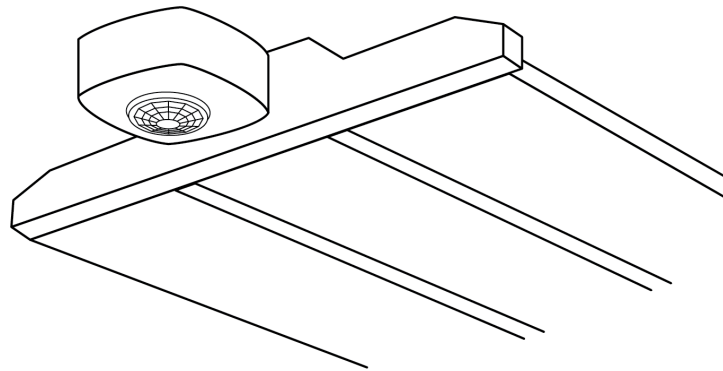
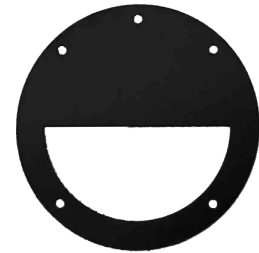

How to Order

Model No.	Description	Input Voltage	Output/Max Load
PSC-BL-I-FM-100-BLE-CB	Passive Infrared (PIR) Occupancy Sensor with relay, lens ordered separately, Casambi Wireless Mesh	100-277VAC	0-10VDC (Dimming) 240VA @ 120VAC, 2A E-Ballast 554VA @ 277VAC, 2A E-Ballast
	Accessories		
LBL	Low Bay Lens 8-30 ft Fresnel Lens		
HBL	High Bay Lens 20-40 ft Fresnel Lens		
ARM	Mounting Arm		
AL1	Masking—Center Aisle Lens Cover		
AL2	Masking—End of Aisle Lens Cover		